



GENESIS GV70 Electric

Emergency Response Guide



GENESIS HELP LINE
0800 HYUNDAI (498 632)

⚠ WARNING

- If severe damage causes high-voltage components to become exposed, emergency responders should take appropriate precautions and wear appropriate insulated personal protective equipment.
- Do not attempt to remove the safety plug while standing in the water.
- Never cut or disconnect the high voltage orange cabling and connectors without first disabling the system by removing the safety plug.
- Exposed cables or wires may be visible inside or outside the vehicle. Never touch the wires, cables, connectors, or any electric components before disabling the system, to prevent injury or death due to electrical shock.

Failure to follow any of these instructions may result in serious injury or death by electrocution.

- Do not cut through any component of the Airbag (SRS) system (Supplementary Restraint System)
- SRS components may remain powered and active for up to 3 minutes after the 12V electrical system is shut off or disabled.

Disconnect the battery negative cable and wait for at least 3 minutes before beginning work.

Failure to follow any of these instructions may result in serious injury or death from accidental deployment of the airbag system.

This manual includes information titled as DANGER, WARNING, CAUTION & NOTICE.

These titles indicate the following:

DANGER

DANGER indicates a hazardous situation which, if not avoided, will result in death or serious injury.

WARNING

WARNING indicates a hazardous situation which, if not avoided, could result in death or serious injury.

CAUTION

CAUTION indicates a hazardous situation which, if not avoided, could result in minor or moderate injury.

NOTICE

NOTICE indicates a situation which, if not avoided, could result in vehicle damage.

WARNING

- If severe damage causes high-voltage components to become exposed, emergency responders should take appropriate precautions and wear appropriate insulated personal protective equipment.
- Do not attempt to remove the safety plug while standing in the water.
- Never cut or disconnect the high voltage orange cabling and connectors without first disabling the system by removing the safety plug.
- Exposed cables or wires may be visible inside or outside the vehicle. Never touch the wires, cables, connectors, or any electric components before disabling the system, to prevent injury or death due to electrical shock.

Failure to follow any of these instructions may result in serious injury or death by electrocution.

- Do not cut through any component of the Airbag (SRS) system (Supplementary Restraint System)
- SRS components may remain powered and active for up to 3 minutes after the 12V electrical system is shut off or disabled. Disconnect the battery negative cable and wait for at least 3 minutes before beginning work.

Failure to follow any of these instructions may result in serious injury or death from accidental deployment of the airbag system.

This manual includes information titled as DANGER, WARNING, CAUTION & NOTICE.

These titles indicate the following:

DANGER

DANGER indicates a hazardous situation which, if not avoided, will result in death or serious injury.

WARNING

WARNING indicates a hazardous situation which, if not avoided, could result in death or serious injury.

CAUTION

CAUTION indicates a hazardous situation which, if not avoided, could result in minor or moderate injury.

NOTICE

NOTICE indicates a situation which, if not avoided, could result in vehicle damage.

WARNING

- If severe damage causes high-voltage components to become exposed, emergency responders should take appropriate precautions and wear appropriate insulated personal protective equipment.
- Do not attempt to remove the safety plug while standing in the water.
- Never cut or disconnect the high voltage orange cabling and connectors without first disabling the system by removing the safety plug.
- Exposed cables or wires may be visible inside or outside the vehicle. Never touch the wires, cables, connectors, or any electric components before disabling the system, to prevent injury or death due to electrical shock.

Failure to follow any of these instructions may result in serious injury or death by electrocution.

- Do not cut through any component of the Airbag (SRS) system (Supplementary Restraint System)
- SRS components may remain powered and active for up to 3 minutes after the 12V electrical system is shut off or disabled. Disconnect the battery negative cable and wait for at least 3 minutes before beginning work.

Failure to follow any of these instructions may result in serious injury or death from accidental deployment of the airbag system.

Contents

Important Safety Information	1 / 2
Introduction	3
Genesis GV70 Identification	4
- General Vehicle Description	4
- Identifying a Genesis Electric Vehicle	4
Genesis GV70 Main Systems	6
- Vehicle Components	12
- Airbag System (SRS : Supplemental Restraint System)	14
Emergency Procedures	16
- Initial response: Identify, Immobilise & Disable	16
- Vehicle Lifting / Jacking Points	21
- Extraction Operations	22
- Submersion	23
- Vehicle Fire	24
- High-Voltage Battery Damage & Fluid Leaks	25
Roadside Assistance	27
- Towing	27
- Jump Starting	28



Document Purpose

The purpose of this document is to familiarise emergency responders and the towing/roadside assistance industry with the proper methods to handle the Genesis GV70 Electric in an emergency situation. This guide offers a basic overview of key vehicle systems and provides instructions for dealing with the different types of situations encountered by emergency responders. The emergency response procedures for this vehicle are somewhat similar to a conventional vehicle with additional information provided on dealing with the high-voltage electrical system.

Vehicle Description

An electric vehicle is driven using a battery and an electric motor. While general vehicles use an internal combustion engine and gasoline as fuel, electric vehicles use electrical energy that is charged inside the high voltage battery. As a result, electric vehicles are eco-friendly in that they do not require fuel and do not emit exhaust gases. When decelerating or driving downhill, regenerative braking is utilized to charge the high voltage battery. This minimizes energy loss and increases the Distance to Empty (DTE). AC Slow (Portable Charger), AC Fast (Wall Mounted Home Charger) & DC Rapid / Hyper Charger (National Public Network) are all supported.



General Vehicle Description

The Genesis GV70 Electric is built on the new e-GMP (Global Modular Platform) developed by Hyundai. The exterior design is very distinctive and stands out to conventional vehicles. Using the information provided in this section, emergency responders will be able to easily identify Genesis GV70.

Identifying a Hyundai Electric Vehicle

Electric badge on Boot and Blue Drive badge on side of Vehicle

The Genesis GV70 Electric can be easily identified by its unique exterior design and by the “Genesis” & “GV70” badge located on the tail gate.

⚠ DANGER

Electrocution Risk

Badging can become hidden after a crash due to damage to the vehicle. Always be sure to utilize additional methods if identification before determining there is no badge present.



GV70 logo

Genesis logo



VIN Number

The Vehicle Identification Number (VIN) identifies the Electric Vehicle with a “G” / ”H” displayed in the 8th position, as shown in the below image. (under driver’s seat)

The VIN is punched on the floor under the driver seat. The “number 1” in the 8th character of the VIN indicates that it is an electric vehicle with battery.

- 1 = Battery [Li-ion 697 V, 111.2 Ah & 77.4 Kwh] + Motor [3-phase AC 160 kW (front) + AC 160 kW (Rear)]



VIN Example - KMTMA81RPU004298

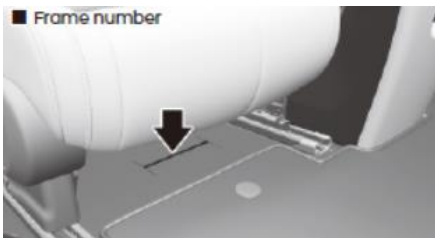

Under Driver's Seat

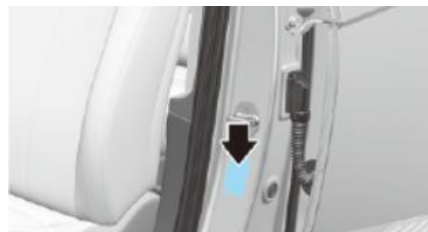

Passenger Side "B" Pillar



Passenger Side Front Windscreen

Motor Compartment

The GV70 Electric has a plastic power electric covers & storage.



Additionally, there are orange colored high-voltage electrical cables in the motor compartment on the right side.



Identifying a Hyundai Electric Vehicle

Vehicle Underside

An orange-colored cable covered by the under cover is also visible on the underside of the vehicle.



Electric Vehicle Cluster Instrument Panel

The Electric Vehicle Instrument Cluster Panel displays the electric vehicle specific features that identify as an electric vehicle.

1 : Regeneration brake /charge/power gauge

2 : SOC – State of Charge of the high voltage battery.

3 : The **“Ready”** Light indicates the vehicle is ready for driving.

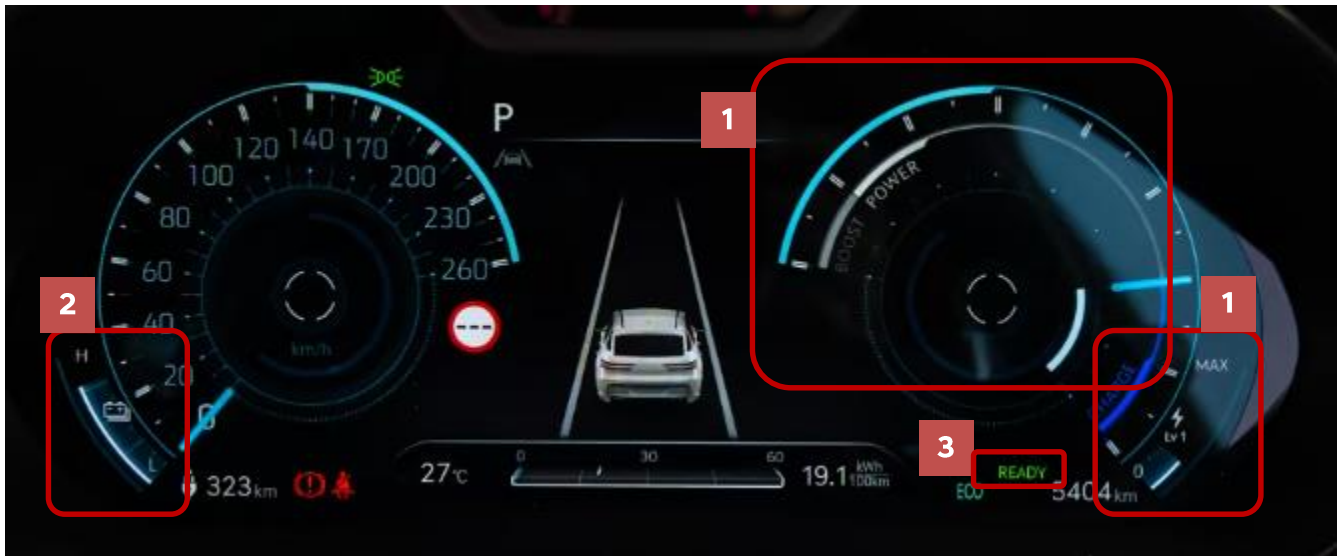

Key Specifications

Item		Electric	
		77.4 kWh	
		All-Wheel Drive (AWD)	
Motor	Type	Permanent Magnet Synchronous Motor	
	Max. Output (kW)	160 (front) + 160 (rear)	
	Max Torque (Nm)	350 (front) + 350 (rear)	
Reduction Gear	Maximum torque (Nm)	395 + 395	
	Gear Ratio	10.65	
EPCU	Inverter	Input Voltage(V)	245 ~ 421V
OBC (On Board Charger)		Max. Output (kW)	10.5 kW
High Voltage Battery	Type	77.4 kWh	
		Lithium-ion polymer	
	Rated Voltage (V)	697 V	
	Capacity (Ah) / Energy (kwh)	111.2 / 77.4	
	Number for Cells	192-cell (2P6S*32)	
		Weight (kg)	480

General Vehicle Description

The safest method is to assume that Genesis GV 70 EV you respond to is an electric vehicle. Using the information provided in this section, responders will be able to differentiate between the two.

Charging Port

The Charging Port is located on the side outer panel covered by the charging port cap and it has one port for AC normal, fast and trickle charging.

How to open the charging port



1. Depress the brake pedal and apply the parking brake.
2. Turn OFF all switches, shift to P (Park), and turn OFF the vehicle.
3. Push the charging door where the icon is located to open. The charge door opens only when the door is unlocked until 2 minutes after turn OFF.
4. Remove the charging inlet cover. AC or DC

Disconnect the EV Charging Connector Charging Port in Emergency



1. Open the bonnet.
2. "pull-up" the emergency release cable to disconnect the EV Charging Connector from vehicle charge port.

WARNING

Electrocution Risk!

- Never cut or disconnect the high voltage orange cabling and connectors without first disabling the system by removing the safety plug.
- Exposed cables or wires may be visible inside or outside the vehicle. Never touch the wires, cables, connectors, or any electric components before disabling the system, to prevent injury or death due to electrical shock.

Failure to follow these instructions can lead to death by electrical shock.

Vehicle Components Location

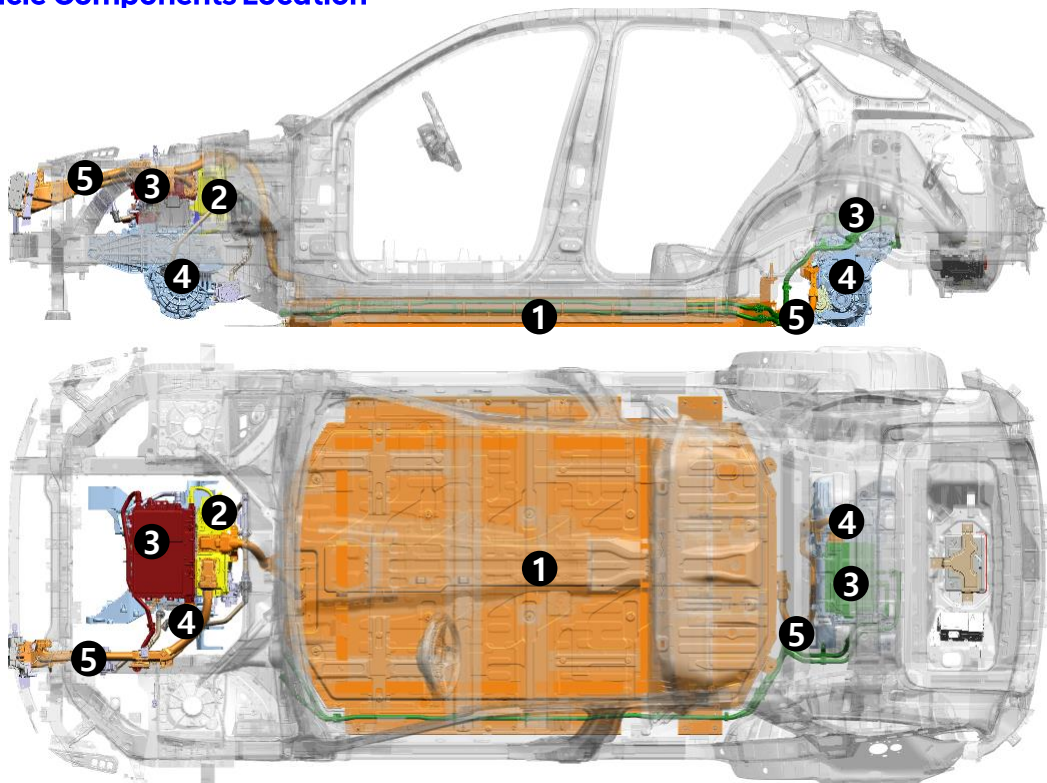

1	High voltage battery	Supplies electric energy to traction motor and stores generated electric energy.	
2	High-voltage Junction box (FRT, RR)	It supplies electricity from battery to the inverter, LDC, air conditioner compressor, etc...	
3	ICCU (OBC + LDC)	Integrated Charging Control Unit (OBC + LDC) OBC (On-Board Charger) : Battery charging equipment (AC→DC) LDC (Low Voltage DC-DC Converter) : Charge 12V auxiliary battery	
4	Drive System	Motor	When current flows through the coil, it generates a rotating magnetic field and generates motor torque.
		EV Transmission	Increases Motor Torque and increased Torque is transferred to the wheels.
		Inverter	DC → AC (from battery to traction motor) AC → DC (charge using regenerative braking)
5	High-Voltage Cable	The high-voltage cabling is orange per the SAE standard.	

High-Voltage Electrical Isolation

Unlike the 12V electrical system that is grounded to the vehicle's chassis, the GV70's high-voltage electrical system is designed to be isolated from the vehicle.

Regulation of High-Voltage Electrical Current

The Power Relay Assembly (PRA) is mounted rear side of the High-Voltage Battery Pack Assembly and controls the high-voltage power circuit between the High-Voltage Battery and the Electric Power Control Unit.

High-Voltage Safety System

There are multiple safety systems incorporated into the GV70. The system that protects the High-Voltage Electrical System is called the Battery Management Unit (BMU). The BMU is located beside the Power Relay Assembly and measures several parameters to maintain the optimal performance of the High-Voltage Battery. In addition, if a system fault occurs, the BMU turns off the PRA to protect the system.

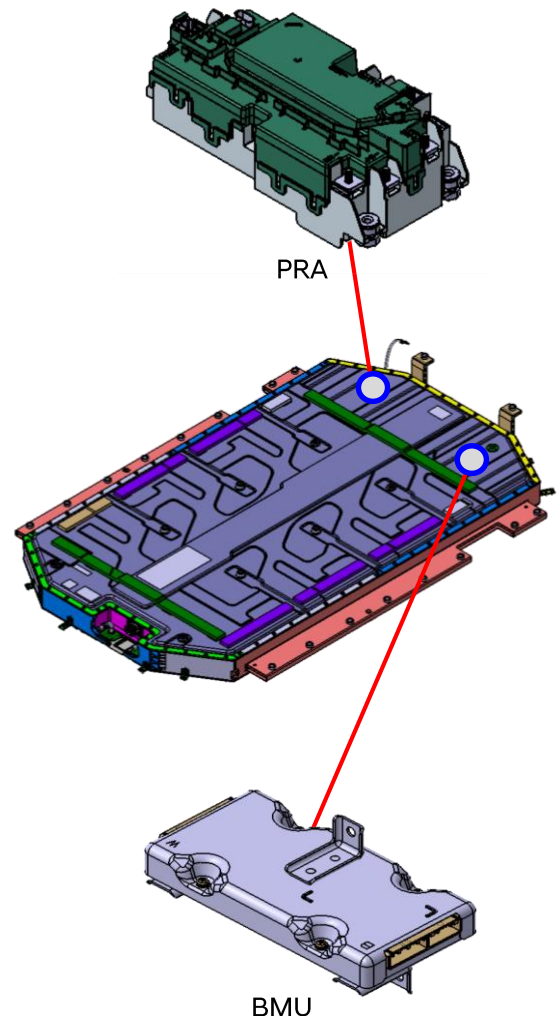

⚠ WARNING Electrocutation Risk!

- Never cut or disconnect the high voltage orange cabling and connectors without first disabling the system by removing the High voltage cut-off Switch.
- Exposed cables or wires may be visible inside or outside the vehicle. Never touch the wires, cables, connectors, or any electric components before disabling the system, to prevent injury or death due to electrical shock.

Failure to follow these instructions can lead to death by electrical shock.

Airbag System (SRS : Supplemental Restraint System)

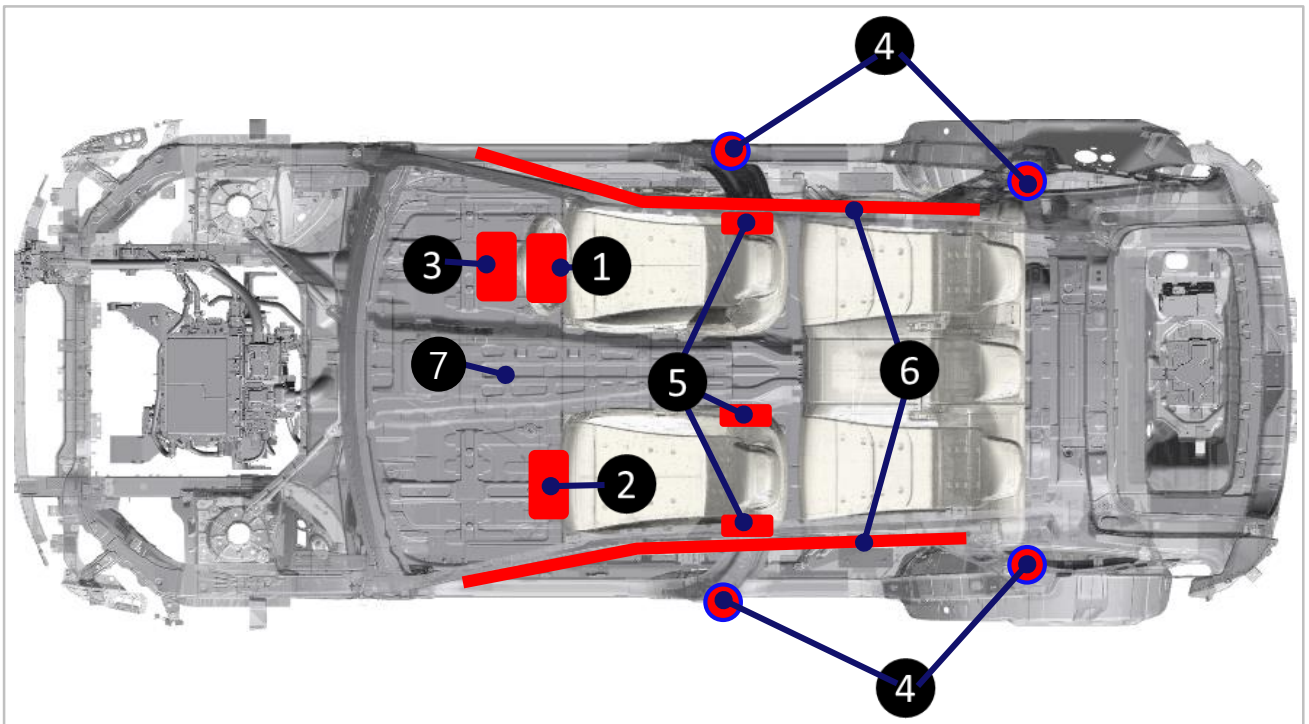
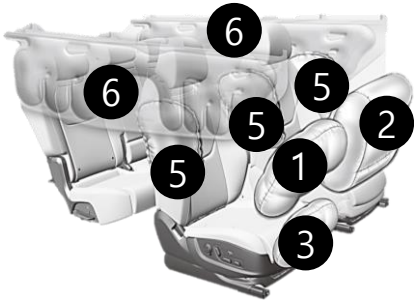

- | | |
|-----------------------------|--|
| 1. Driver's front airbag | 4. Seat Belt Pre-tensioners |
| 2. Passenger's front airbag | 5. Side Airbags & Driver's Centre Airbag |
| 3. Driver's Knee Airbag | 6. Curtain Airbags |
| | 7. Airbag Control Unit |

⚠ WARNING

- Do not cut through any component.
- SRS components may remain powered and active for up to 3 minutes after the 12V electrical system is shut off or disabled. Disconnect the battery negative cable and wait for at least 3 minutes before beginning work.

Failure to follow any of these instructions may result in serious injury or death from accidental deployment of the airbag system.

WARNING

Electrocution Risk!

- Never cut or disconnect the high voltage orange cabling and connectors without first disabling the system by removing the safety plug.
- Exposed cables or wires may be visible inside or outside the vehicle. Never touch the wires, cables, connectors, or any electric components before disabling the system, to prevent injury or death due to electrical shock.

Failure to follow these instructions can lead to death by electrical shock.

Initial Response:

The following procedures should be used whenever you are dealing with a GV70 at an emergency scene. All other operations should be consistent with your department's standard operating procedures or guides. Electric vehicles damaged by a crash may have compromised high voltage safety systems and present a potential high voltage electrical shock hazard. Exercise caution and wear appropriate personal protective equipment (PPE) safety gear, including high voltage safety gloves and boots. Remove all metallic jewelry, including watches and rings.

Identify

When dealing with a GV70 at the scene of an accident, emergency responders should always assume that it is a electric model until it can be proven otherwise using the identification features outlined in this ERG. Always be sure to inspect multiple sides of the vehicle as well as using the clues found under the hood and in the interior of the vehicle.



Immobilise

The next step is to immobilize the vehicle to prevent any accidental movement that can endanger the emergency response personnel and any crash victims. Since the GV70 doesn't have an engine, there will be instances where the vehicle appears to be off because of the absence of engine noise. When in its "ready" mode, the vehicle can move almost silently using the electric motor.

Responders should approach the vehicle from the sides and stay away from the front or rear as they are both potential paths of travel. Instructions for immobilizing the vehicle are shown below.



Press "P" button



Engage Parking Brake



Press START/STOP Button



Chock the Wheels

*** The actual image of vehicle may differ from the illustration**

Disable

The final step in the initial response process, conducted after the vehicle is secured to prevent movement, is to disable the vehicle, its SRS components and the high voltage electrical system. To prevent current flow through the system, use one of the following procedures to disable the vehicle.

Disabling the system – Smart Key System and EV START/STOP BUTTON

1. Check the status of the READY light on the instrument panel. If the READY light is illuminated, the vehicle is on.

a) If the READY light is NOT illuminated, the vehicle is off, Do not push the EV START/STOP button because the vehicle may restart.

b) To turn off the system, put the shift lever in the P (Park) position and press the EV button beside the shift lever.



EV START/STOP Button

Without depressing the brake pedal

Pressing EV Start/Stop button	Button Position	Vehicle Condition
	OFF	Off
One time	ACC	Electrical accessories are operational.
Two times	ON	The warning lights can be checked before the vehicle is started.
Three times	OFF	Off

Depressing the brake pedal while a shift lever is in the P (Park) position

Pressing EV Start/Stop button	Button Position	Vehicle Condition
	OFF	Off
One time	-	Ready to drive

2. Before disconnecting the 12V battery, move the smart key at least 2 meters away from the vehicle to prevent accidental restart.



Smart Key

3. Disconnect the negative (-) 12V battery cable located in the “boot, under the luggage tray”, to further prevent the risk of accidental restart.

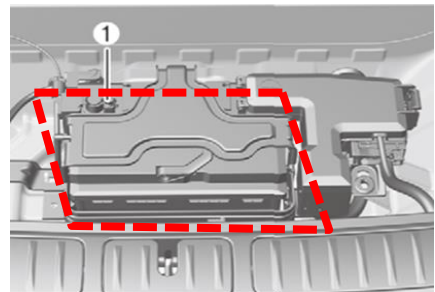

NOTICE

If necessary, lower the windows, unlock the doors and open the boot as required, before disconnecting the 12V battery. Once the 12V battery is disconnected, power controls will not operate.

4. Use the following procedure to isolate the high voltage of the battery.

4-1. Remove the High voltage cut-off Switch located in the low voltage junction block.

- a) Remove the Junction block upper cover
ⓐ in the “engine bay”.



- b) Disconnect the High voltage cut-off Switch
using the following procedure :

① : Pull the label → ② : Disconnect

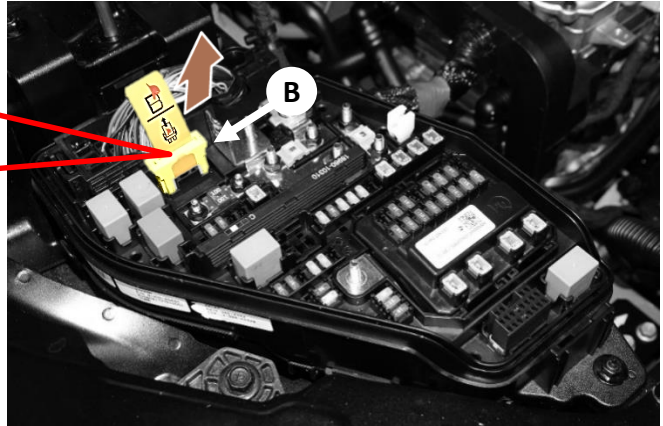
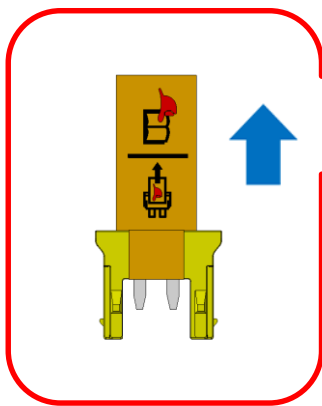

High voltage cut-off Switch

If this method of disabling system is unsuccessful, the vehicle is not secured from accidental deployment of airbags and electric shock from high-voltage components.

⚠ WARNING Electrocutation Risk!

- Before engaging in emergency response procedures, ensure the vehicle is disabled and wait for more than 5 minutes to allow the capacitor in the high voltage system to discharge to avoid electrocution.
- Exposed cables or wires may be visible inside or outside the vehicle. To prevent injury or death due to electrical shock, never touch the wires or cables before disabling the system, to prevent injury or death due to electrical shock.

Failure to follow any of these instructions may result in serious injury or death by electrocution.

⚠ WARNING Explosive Risk!

- Do not cut through any component.
- SRS components may remain powered and active for up to 3 minutes after the 12V electrical system is shut off or disabled. Disconnect the battery negative cable and wait for at least 3 minutes before beginning work.

Failure to follow any of these instructions may result in serious injury or death from accidental deployment of the airbag system.

Vehicle Lifting / Jacking Points

The lifting or jacking up of Genesis GV70 is similar to the conventional vehicle. However, the first responder should pay special attention when they extract occupants in the vehicle. Before any lifting operations, the first responders should carry out

“Initial Response : **Identify, Immobilise and Disable**” procedure section from page 16 ~ 21.

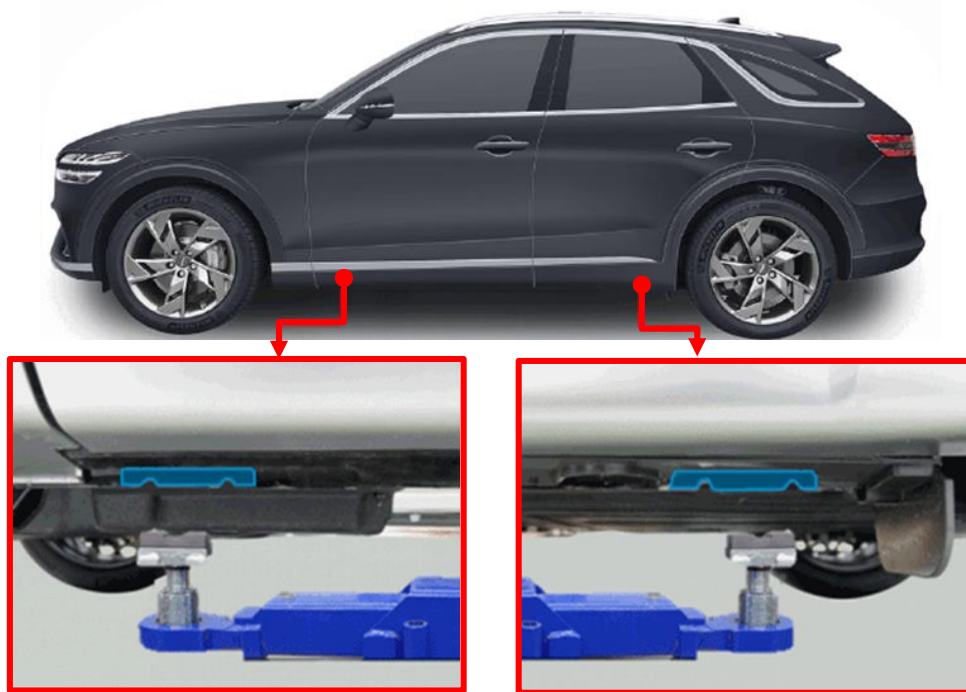

Vehicle Stabilisation

Use standard stabilisation (cribbing) points, as shown. Always be sure to connect to a structural member of the vehicle and avoid placing cribbing under high voltage cables, fuel lines and other areas not normally considered acceptable.









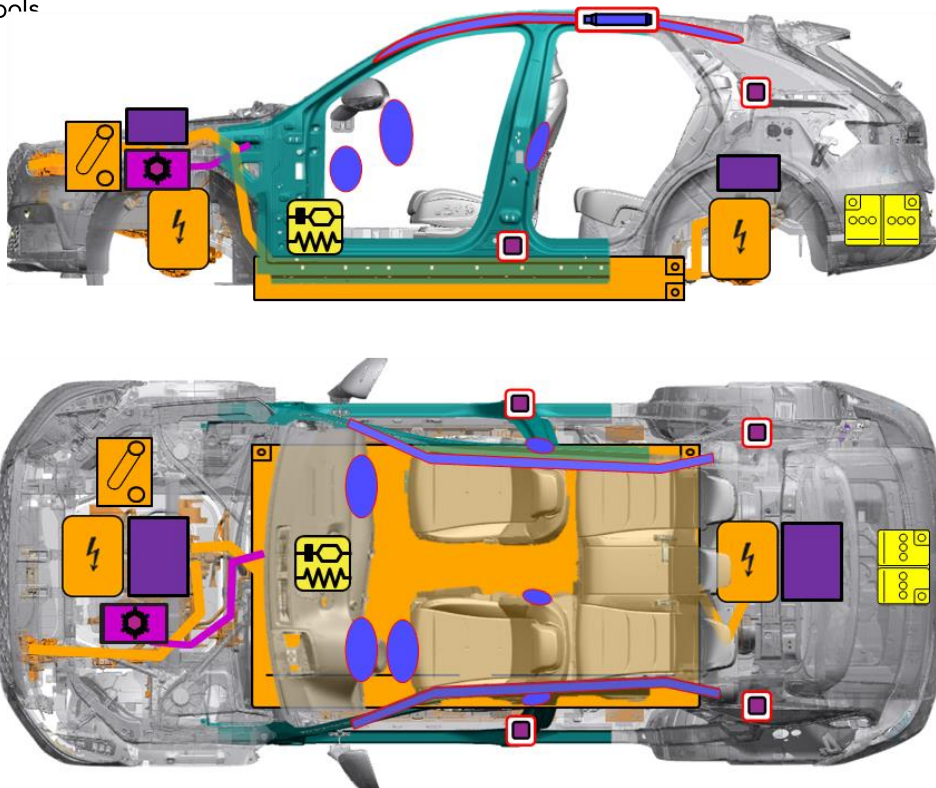



Extrication Procedure

When responding to an incident involving the Genesis GV70, we recommend that the first responders follow their organisation’s standard operating procedures for assessing and dealing with vehicle emergencies.

When the first responders cut the vehicle, they should always pay special attention to airbag system, orange colored high voltage cables and other high voltage components as below image to avoid damage to parts which may increase the risks of explosion.

“green” marked zones is Hot Stamped Steel (Ultra High Strength). So this zone can not be cut with general tools



 Supplemental Restraint System Control Module (SRSCM)	 Airbag	 Airbag Gas Inflators
 High voltage cable	 12V Battery	 Air-conditioning line
 High voltage disconnect	 OBC (On – Board Charger)	 Ultra-High Strength Steel
 High Voltage Battery	 Air-conditioning component	 Seat belt pretensioner

Location of Ultra-high Strength Steel

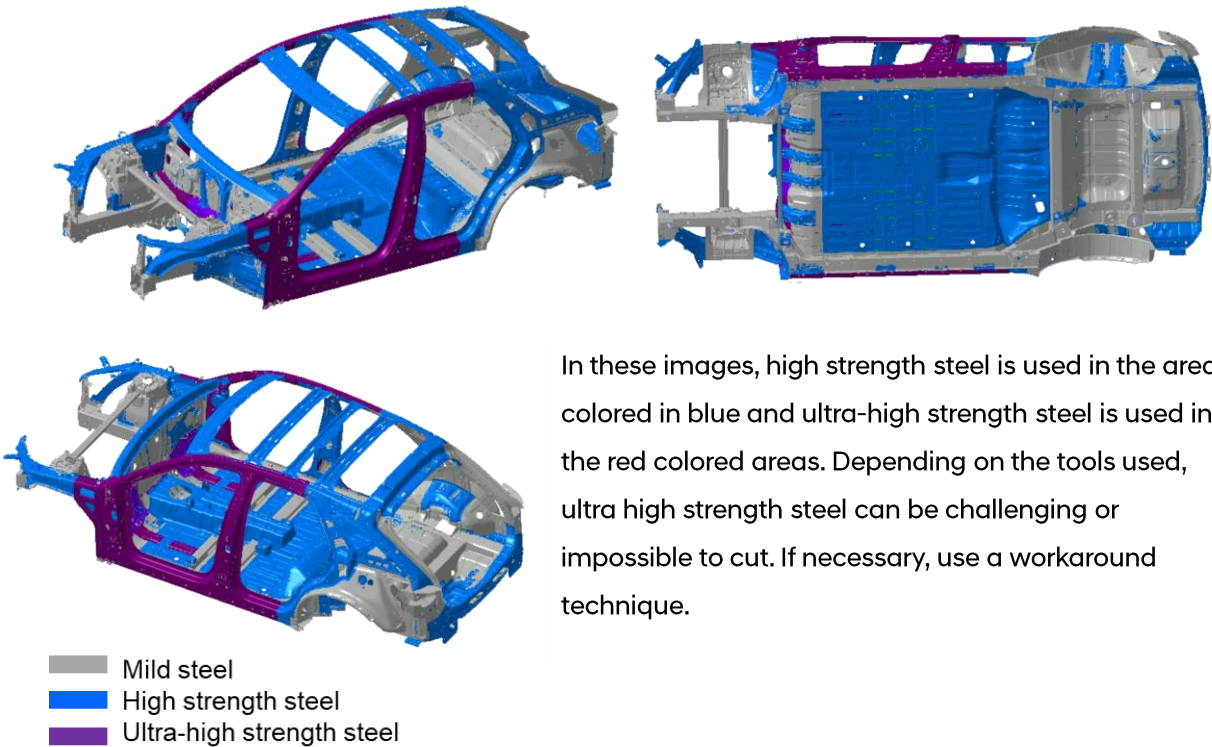

In these images, high strength steel is used in the areas colored in blue and ultra-high strength steel is used in the red colored areas. Depending on the tools used, ultra high strength steel can be challenging or impossible to cut. If necessary, use a workaround technique.

Submersion

Some emergency responses can involve a submerged vehicle. A GV70 that is submerged does not have high-voltage component on the vehicle's body or framework. It is safe to touch the vehicle's body or framework if there is no severe damage to the vehicle, whether it is in water or on land. In the event the vehicle is submerged or partially submerged, remove the vehicle from the water before attempting to disable the vehicle. Drain the water from the vehicle. Use one of the methods described in sections of page 16 ~ 21 to disable the vehicle.

⚠ WARNING

- If severe damage causes high-voltage components to become exposed, responders should take appropriate precautions and wear appropriate insulated personal protective equipment. Failure to follow any of these instructions may result in serious injury or death by electrocution.

Vehicle Fire

After Initial Emergency Response Procedures have been applied, Firefighting Procedures may begin. Hyundai recommends that each response team follow their own department's standard operating procedures for fighting vehicle fires in combination with the GV70 specific details that are covered in this section.

Firefighting Operations

If the high-voltage battery pack is either involved in or at risk of being involved in a fire in a IONIQ 5, strict cautions must be taken while conducting firefighting operations due to following reasons:

- Lithium-ion Polymer batteries contain gel electrolyte that can vent, ignite, and produce sparks when subjected to temperatures above 300°F / 150°C.
- May burn rapidly with a flare-burning effect.
- Even after the high-voltage battery fire appears to have been extinguished, renewed or delayed fire can occur.
 - Use a thermal imaging camera to ensure the high voltage battery is completely cooled before leaving the incident.
 - Always advise second responders that there is a risk of the battery re-igniting.
 - Fire, submersion or a collision that has compromised the high voltage battery, always store it in an open area with no exposures within 50 feet.
- A burning battery could release hydrogen fluoride, carbon monoxide, and carbon dioxide gasses. Use NIOSH/MSHA approved full-face self-contained breathing apparatus (SCBA) with full protective gear.

Even if the high-voltage battery pack is not directly involved in a vehicle fire, approach the vehicle very carefully.

Extinguishers

- Small fires that high voltage battery is not involved : Extinguish fires using a ABC extinguisher for an electric fire.
- Fires that the high voltage battery is involved or the high voltage battery is heating : Extinguish fires using large and sustained amount of water to cool the high voltage battery. Do not extinguish fire with a small amount of water. Firefighters should not hesitate to pour large amounts of water on the vehicle.

High-Voltage Battery Damage and Fluid Leaks

The HV Battery assembly is enclosed in a sturdy metal case that is rigidly mounted to structural components of the vehicle. This construction helps prevent damage to the HV Battery assembly even in severe crashes. This section provides emergency responders with information regarding how to mitigate the severity of a damaged HV Battery assembly or gel electrolyte spill, however unlikely that might be.

- Cease all smoke, spark, flame activity around the vehicle.
- Electrolyte solution is a skin irritant.
- Do not touch or step on the spilled electrolyte.
- If electrolyte leak occurs, wear appropriate solvent resistant PPE and use oil, sand, or a dry cloth to clean up the spilled electrolyte. Be sure to adequately ventilate the area.

WARNING Irritant Substance Risk!

- Internal components of HV Batteries are irritants and sensitizers.
- To avoid contact with these irritants and sensitizers wear positive pressure self-contained breathing apparatus (SCBA) and other personal protective equipment (PPE) designed for use with these types of hazards.

Failure to wear proper SCBA and PPE can result in serious injury or death

- Electrolyte solution is an eye irritant – If contact with eyes, rinse with plenty of water for 15 minutes.
- Electrolyte solution is a skin irritant. Therefore, if there is contact with skin, wash off with soap.
- Electrolyte liquid or fumes that have come into contact with water vapors in the air will create an oxidized substance. This substance may irritate skin and eyes. In these cases, rinse with plenty of water and see a doctor immediately.
- Electrolyte fumes (when inhaled) can cause respiratory irritation and acute intoxication

Move to a well ventilated location for fresh air and wash mouth with water. See a doctor immediately.

WARNING

Electrocution Risk!

- Never cut or disconnect the high voltage orange cabling and connectors without first disabling the system by removing the safety plug.
- Exposed cables or wires may be visible inside or outside the vehicle. Never touch the wires, cables, connectors, or any electric components before disabling the system, to prevent injury or death due to electrical shock.

Failure to follow these instructions can lead to death by electrical shock.

Towing

If any the loaded wheels or suspension components are damaged or the vehicle is being towed with the rear wheels on the ground, use a towing dolly under the rear wheels.

When being towed by a commercial tow truck and wheel dollies are not used, the rear of the vehicle should always be lifted, not the front.

If emergency towing is necessary, we recommend having it done by an authorized retailer or a commercial tow-truck service.

Proper lifting and towing procedures are necessary to prevent damage to the vehicle.

The use of wheel dollies or flatbed is recommended.

For 2WD vehicles, it is acceptable to tow the vehicle with the front wheels on the ground (without dollies) and the rear wheels off the ground.

CAUTION

- Do not lift vehicle by the tow fitting or body and chassis parts. Otherwise the vehicle may be damaged.
- Do not tow the vehicle with the rear wheels on the ground as this may cause damage to the vehicle.
- Do not tow with sling-type equipment. Use wheel lift or flatbed equipment.



Dollies



Dollies



Jump Starting

1. Position the vehicles close enough that the jumper cables will reach, but do not allow the vehicle body parts to contact.
2. Avoid any moving parts in the “Engine Bay”.
3. Turn off all unnecessary electrical loads.
4. First connect one end of a jumper cable to the positive(+) terminal of the discharged battery in the PE room, then connect the other end to the positive(+) terminal on the booster battery.

Proceed to connect one end of the other jumper cable to the negative(-) terminal of the booster battery, then the other end to a solid, stationary, metallic point away from the battery (for example, the hood latch).

5. Start the vehicle with the booster battery, then start the vehicle with the discharged battery.
6. After a few minutes, turn off the both vehicles.
7. Remove the negative terminal cable first, and then remove the positive terminal cable. If the cause of your battery discharging is not apparent, we recommend that the system be checked by an authorised HYUNDAI Dealer or authorised HYUNDAI Service Agent.

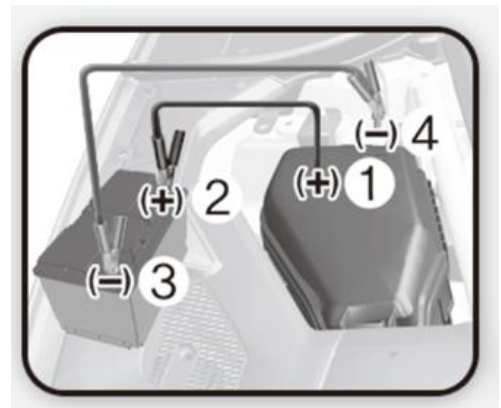
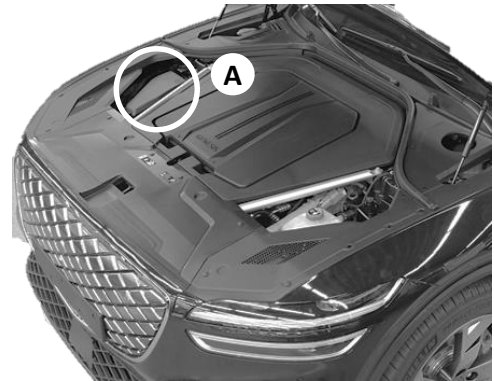

⚠ CAUTION

- Do not connect the cables to or near any part that moves when the vehicle is started.
- Do not allow the jumper cables to contact anything except the correct battery terminals or the correct ground.
- Do not lean over the battery when making connections.



HYUNDAI HELP LINE 0800 HYUNDAI (498 632)

© 2023 (5/2023)

Hyundai Motor Company & Hyundai New Zealand

All rights reserved. This document may not be altered without the written permission of Hyundai Motor Company or Hyundai New Zealand